

## STK01W

### Stapelkit

Stacking kit • Stapelset • Kit de superposition

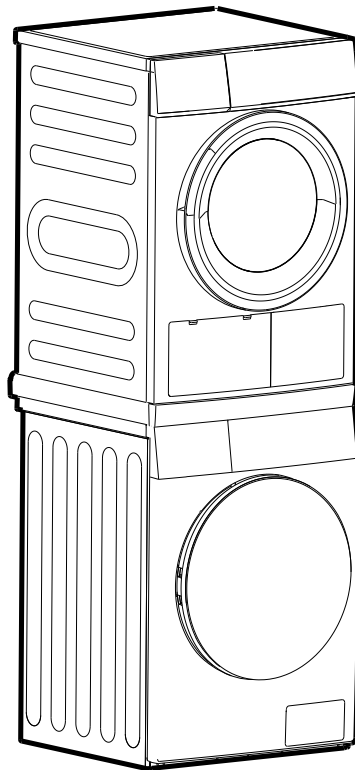

NL • Installatiehandleiding	2
EN • Install user manual	4
DE • Installationsanleitung	6
FR • Manuel d'installation	8

1

AX9:



4X10

BX1:

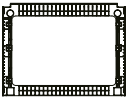

CX1:



DX2:



EX2:



FX2:



GX6:



4X16



Zorg dat de stroomtoevoer is losgekoppeld voordat u het apparaat installeert!

2

AX5:



BX1:



CX1:

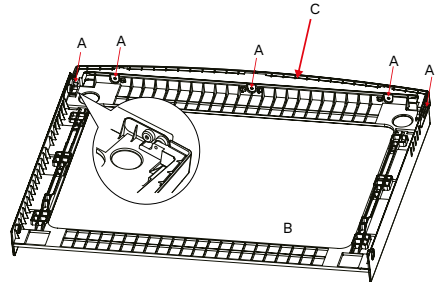

Het aanhaalmoment mag niet hoger zijn dan 5 Nm.

3

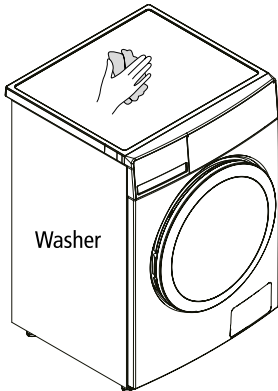

Washer

Reinig de bovenkant van de wasmachine.

4

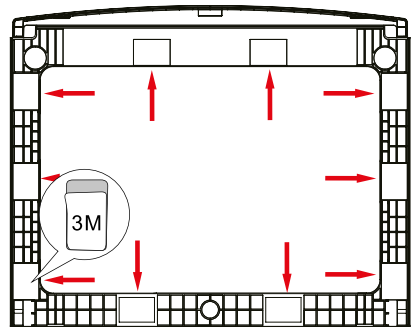

⚠ Let op, verwijder de achterkant van de stickers.

5

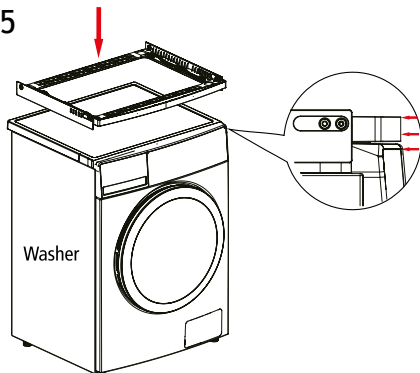

Washer

Opmerking: lijn de beugel B en de wasmachine uit voordat u de beugel B vastplakt met de stickers onderop de beugel.

6

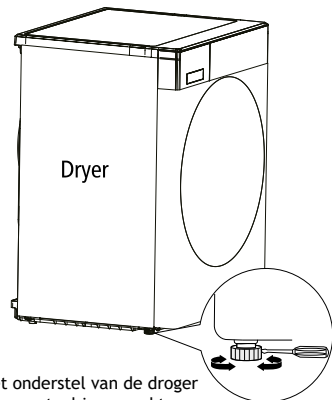

Dryer

Als het onderstel van de droger niet van metaal is gemaakt, zet u de stelpoten van de droger in de laagste stand.

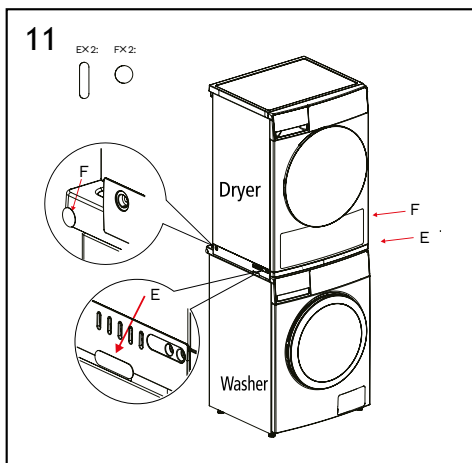
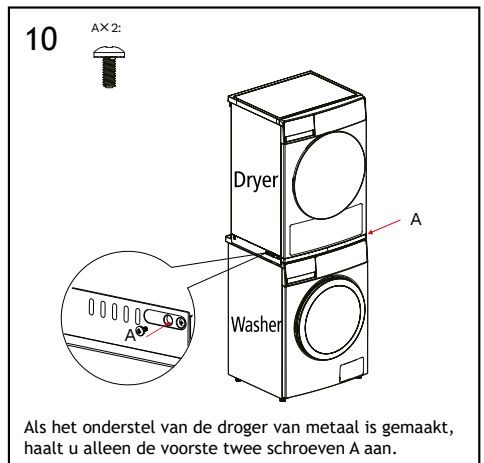
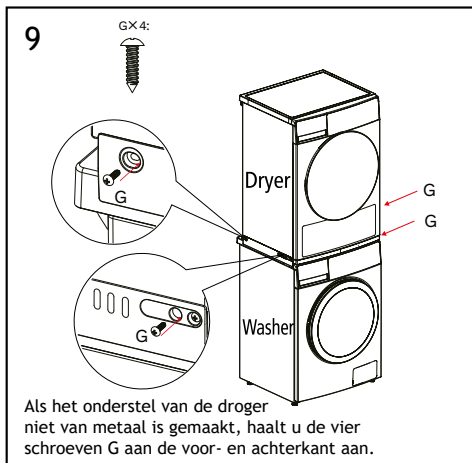
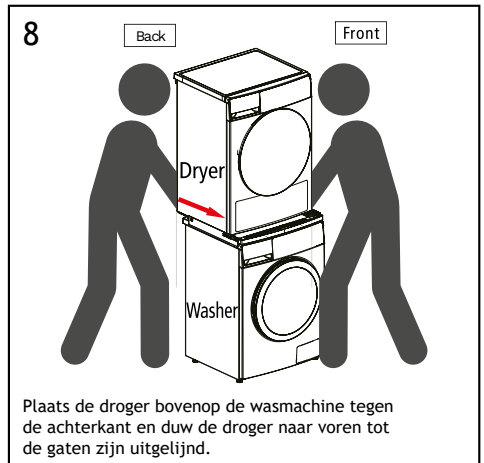
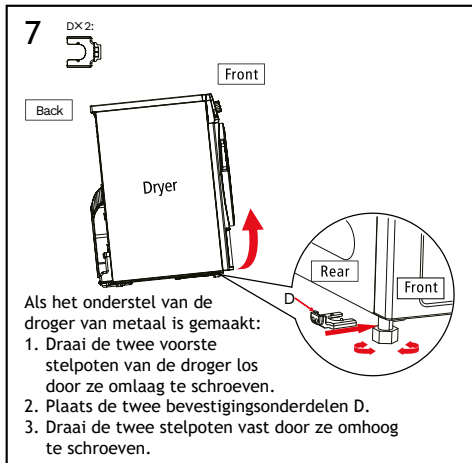

1

AX 9:



4X10

BX 1:

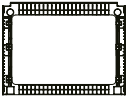

CX 1:



DX 2:



EX 2:



FX 2:



GX 6:



4X16



Make sure that the power supply is disconnected before installation!

2

AX 5:



BX 1:



CX 1:

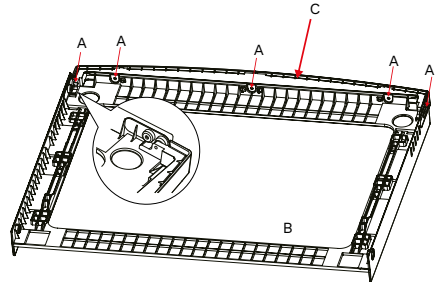

Torque should not exceed 5 N.m

3

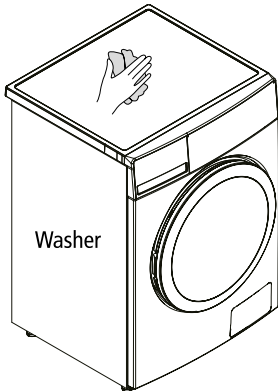

Washer

Clean the top cover of washer

4

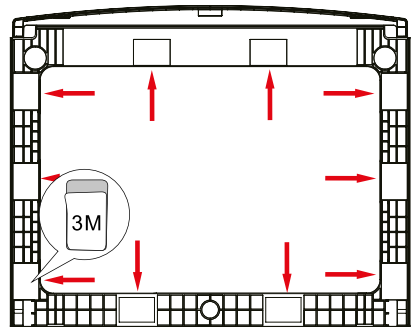

Please note, remove the backing of the stickers

5

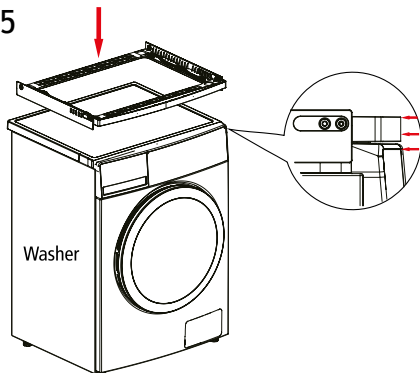

Washer

Note: Align the bracket B and the washing machine before sticking the bracket B with the stickers on the bottom of the bracket

6

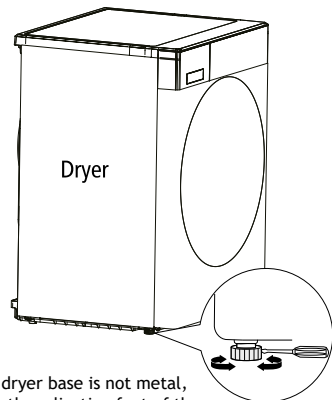

Dryer

If the dryer base is not metal, adjust the adjusting feet of the dryer to the lowest position directly

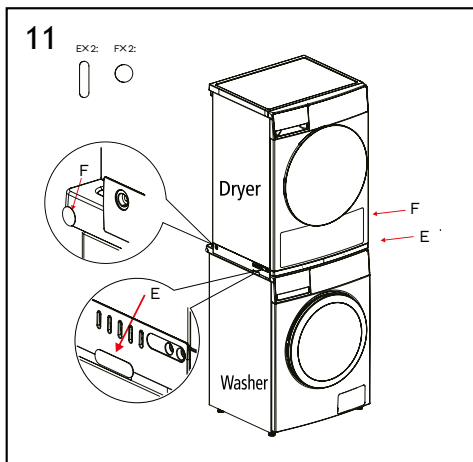
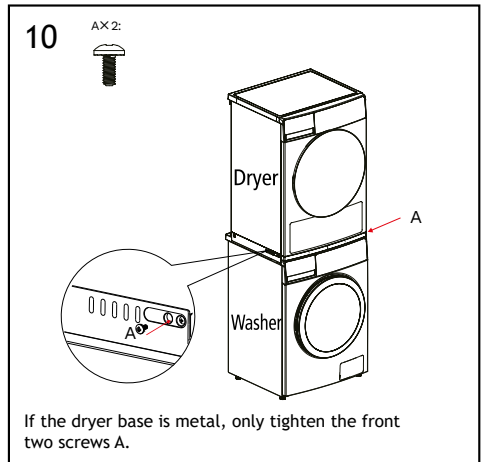
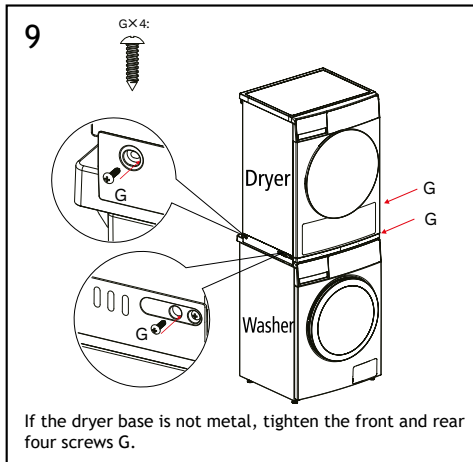
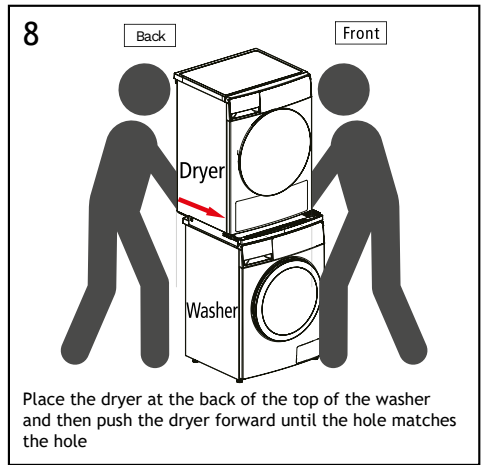
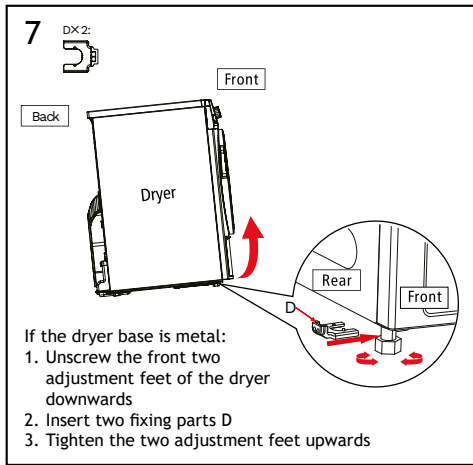

1

AX 9:



4X10

BX 1:

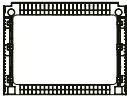

CX 1:



DX 2:



EX 2:



FX 2:



GX 6:



4X16



Die Geräte müssen von der Stromversorgung getrennt sein, bevor Sie das Set installieren!

2

AX 5:



BX 1:



CX 1:

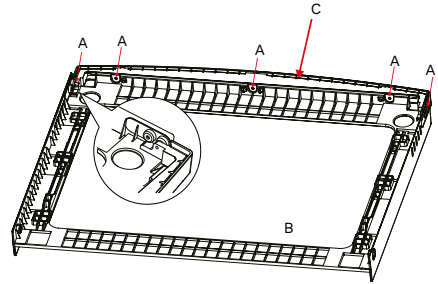

Das Drehmoment darf nicht größer als 5 Nm sein.

3

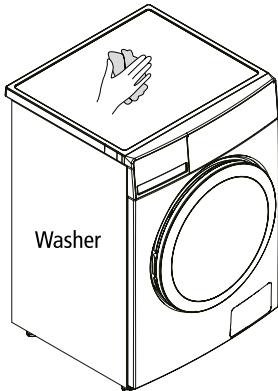

Washer

Reinigen Sie die obere Abdeckung der Waschmaschine.

4

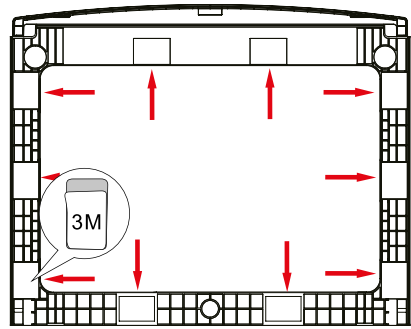

Bitte beachten Sie, dass Sie die Rückseite der Aufkleber entfernen müssen

5

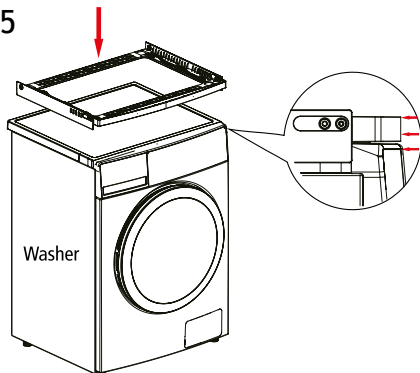

Washer

Hinweis: Richten Sie die Halterung B und die Waschmaschine aus, bevor Sie die Halterung B mit den Aufklebern an der Unterseite der Halterung anbringen.

6

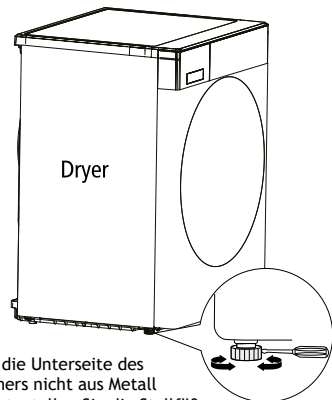

Dryer

Wenn die Unterseite des Trockners nicht aus Metall besteht, stellen Sie die Stellfüße des Trockners direkt auf die niedrigste Position ein.

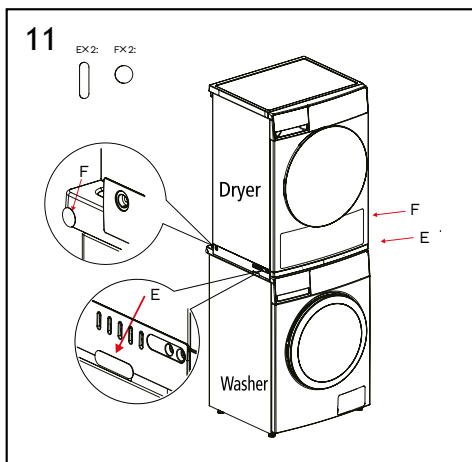
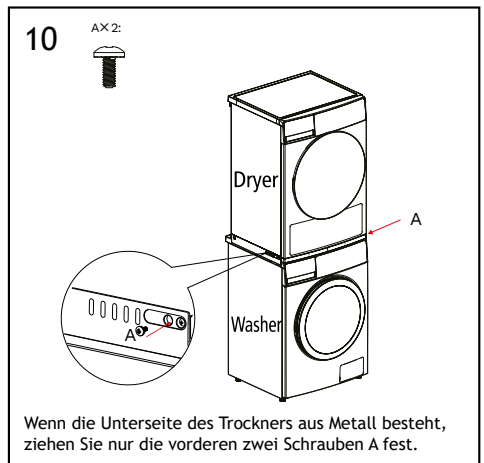
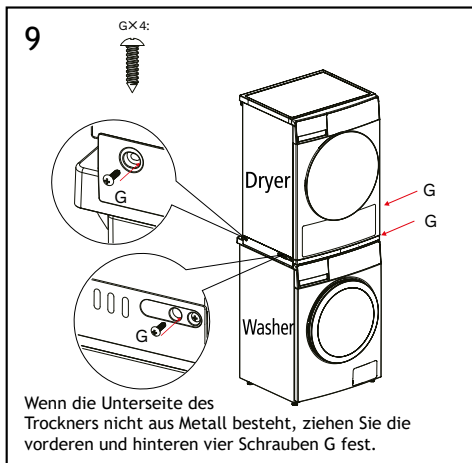
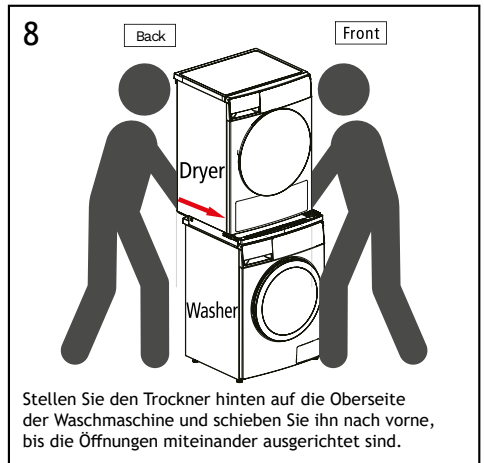
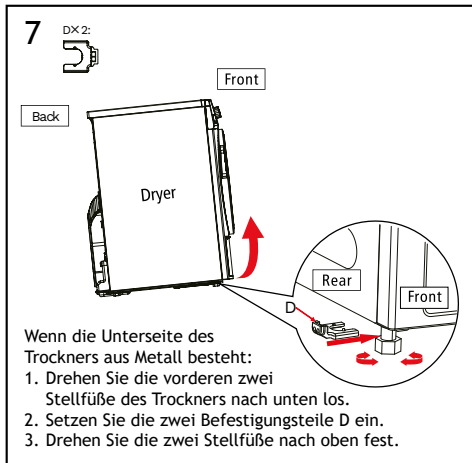

1

AX9:



4X10

BX1:

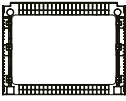

CX1:



DX2:



EX2:



FX2:



GX6:



4X16



Assurez-vous que l'alimentation électrique est déconnectée avant de procéder à l'installation !

2

AX5:



BX1:



CX1:

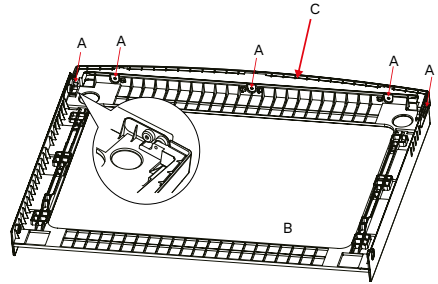

Le couple de serrage ne doit pas excéder 5 N.m.

3

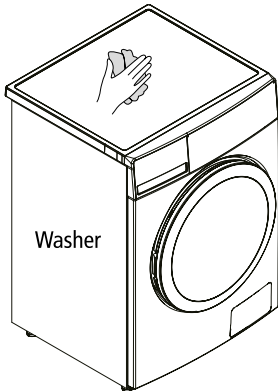

Nettoyez le couvercle supérieur du lave-linge.

4

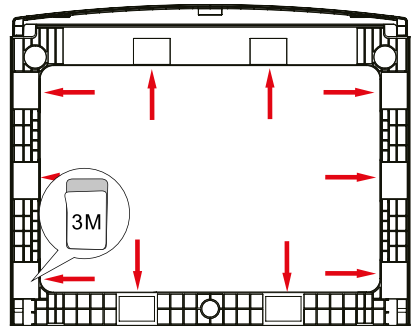

⚠ Attention, retirez le support des autocollants.

5

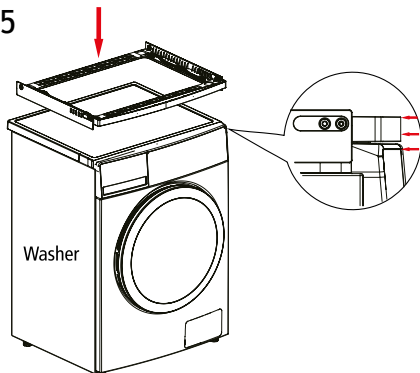

Remarque : Alignez le support B et la machine à laver avant de coller le support B avec les autocollants au bas du support.

6

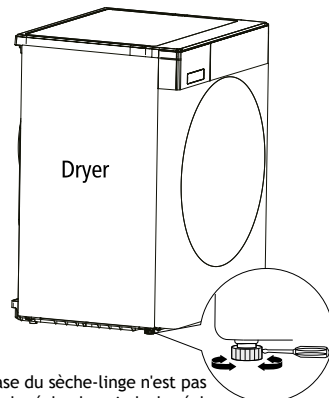

Si la base du sèche-linge n'est pas en métal, réglez les pieds de réglage du sèche-linge à la position la plus basse directement.



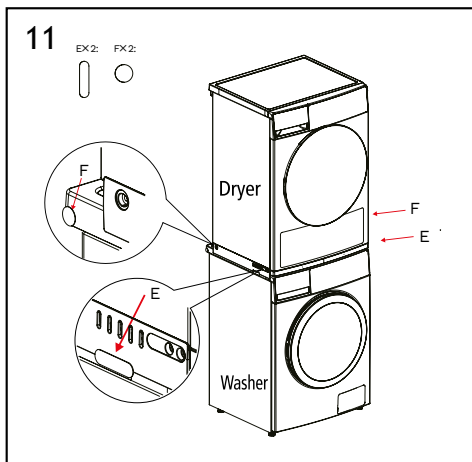
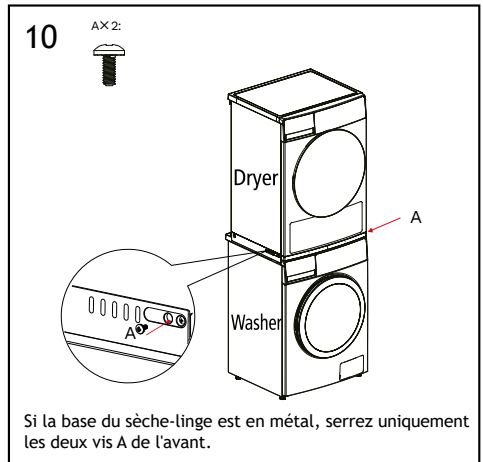
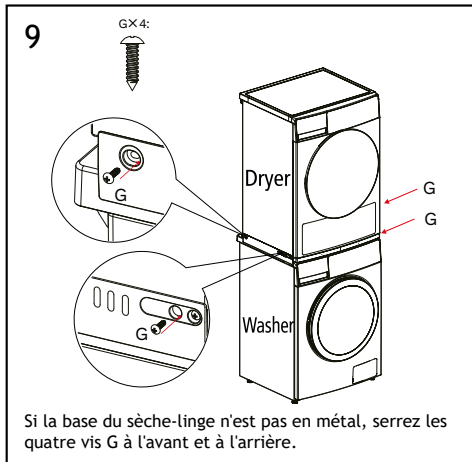
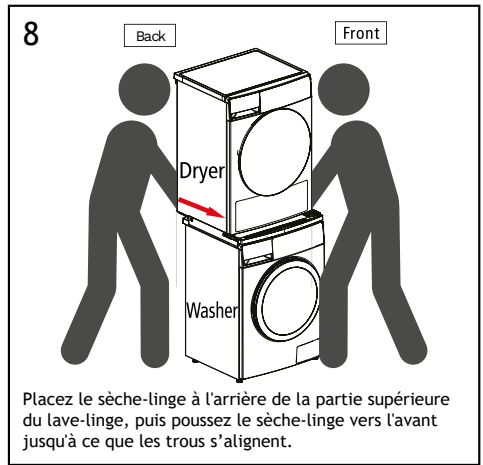
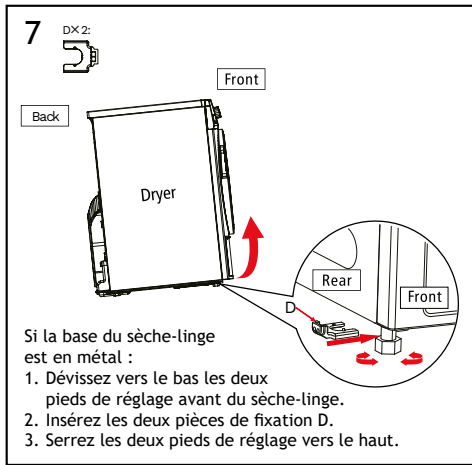





# INVENTUM



STK01W/01.1123  
Wijzigingen en drukfouten voorbehouden  
Modifications and errors reserved  
Änderungen und Druckfehler vorbehalten  
Sous réserve de modifications et d'erreurs d'impression

## INVENTUM

**Inventum Huishoudelijke  
Apparaten B.V.**

Postbus 5023  
6802 EA Arnhem

[www.inventum.eu](http://www.inventum.eu)

[facebook.com/inventum1908](https://facebook.com/inventum1908)  
[pinterest.com/inventum1908](https://pinterest.com/inventum1908)  
[youtube.com/inventum1908](https://youtube.com/inventum1908)  
[instagram.com/inventum1908](https://instagram.com/inventum1908)



[www.inventum.eu](http://www.inventum.eu).....



JAAR  
GARANTIE



BETROUWBARE  
KWALITEIT



UITSTEKENDE  
BEOORDEELD